

# Plastic Cash Tray & Lid



**UNIQUE**  
BUSINESS SYSTEM

## Material Composition

- Manufactured using Injection Grade Polypropylene (PP) Random Copolymer.
- Comparable Resin Grades: SABIC PP QR6701K or equivalent. Comparable
- Resin Grades: LyondellBasell Moplen RP 340N or equivalent. Alternative resin
- grades must meet equivalent technical performance standards. 100% Virgin
- Plastic Material (No recycled or off-spec material used). Natural resin color
- retained without pigments or masterbatch.

## Physical & Mechanical Properties

Property	Range / Value	Standard
Density	> 0.9	ASTM D1238 / ISO 1183
Clarity	Clear to Translucent	-
Tensile Strength (at Yield)	26 – 30 MPa	ASTM D638 / ISO 527-2
Stress at Yield	12 – 14%	ASTM D638 / ISO 527-2
Melt Flow Index (MFI)	10 – 13	ISO 1133
Rockwell Hardness (R Scale)	91 – 94	ASTM D785
Heat Deflection Temperature	75 – 83 °C	ASTM D648

## Strength & Durability

- Designed to withstand falls from heights of 4–5 feet.
- Load bearing capacity of minimum 50 KG without breakage.
- Dimensional tolerance maintained within  $\pm 0.3$  mm.
- Free from molding defects such as flow marks, warpage, ejector marks, streaks, burn marks and weld lines.

## Packaging Information

- Each tray individually packed in protective plastic sheet or bag.
- Supplied in cartons containing 5 trays per carton.

# Plastic Cash Tray & Lid

## *Technical Product Information*



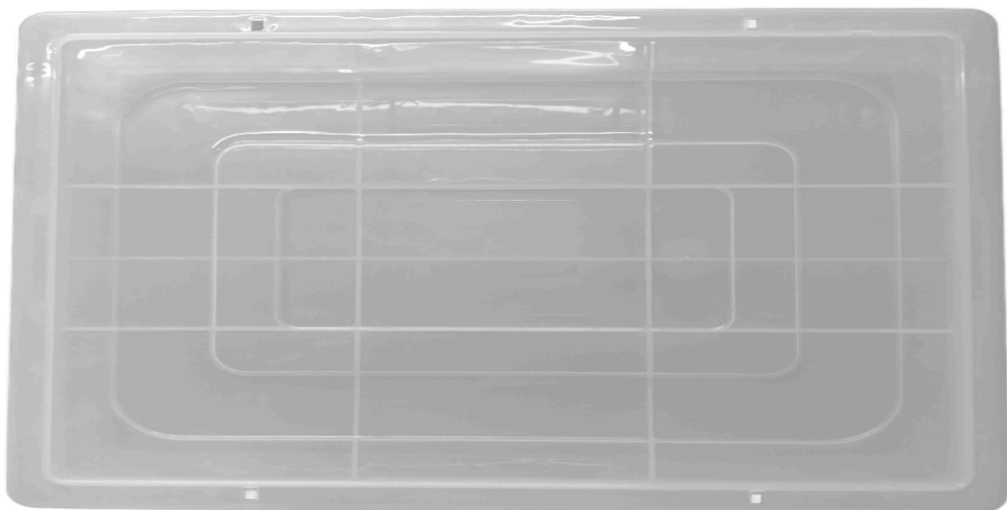

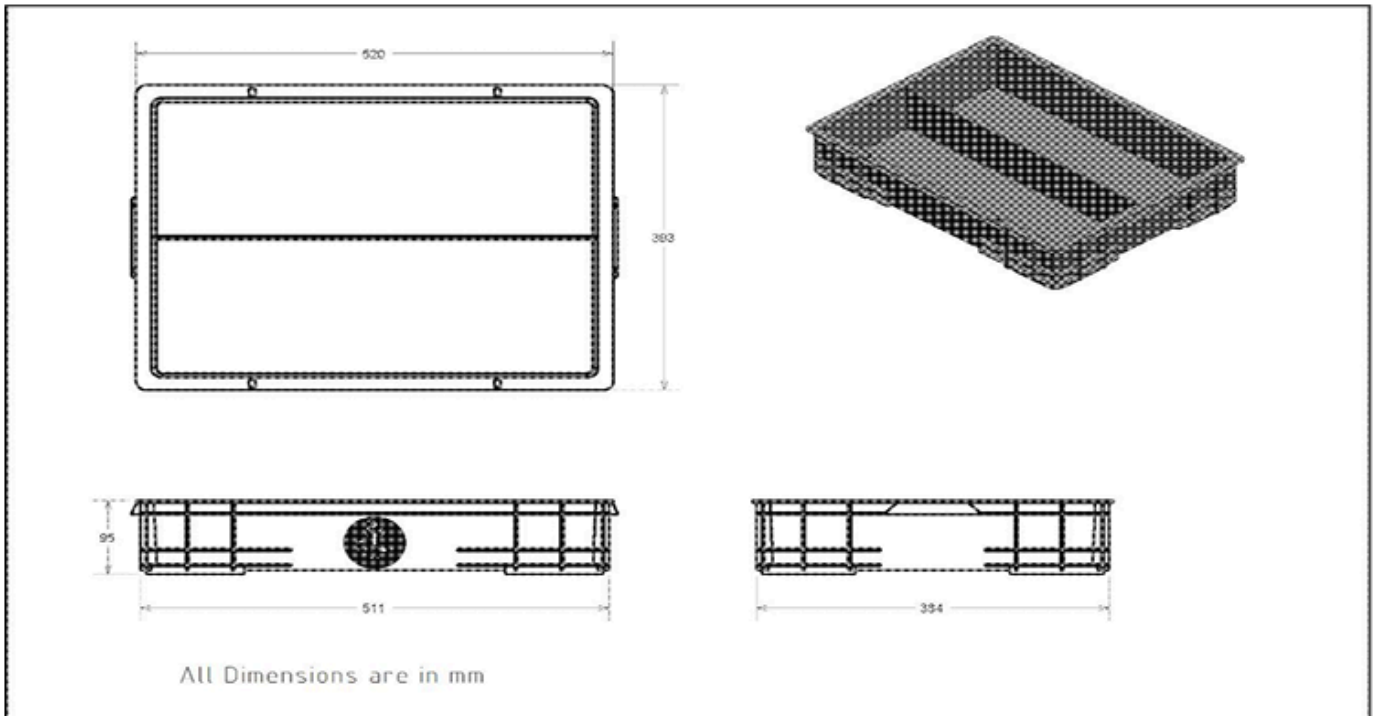

**Batching Details (all Dimensions in mm):**

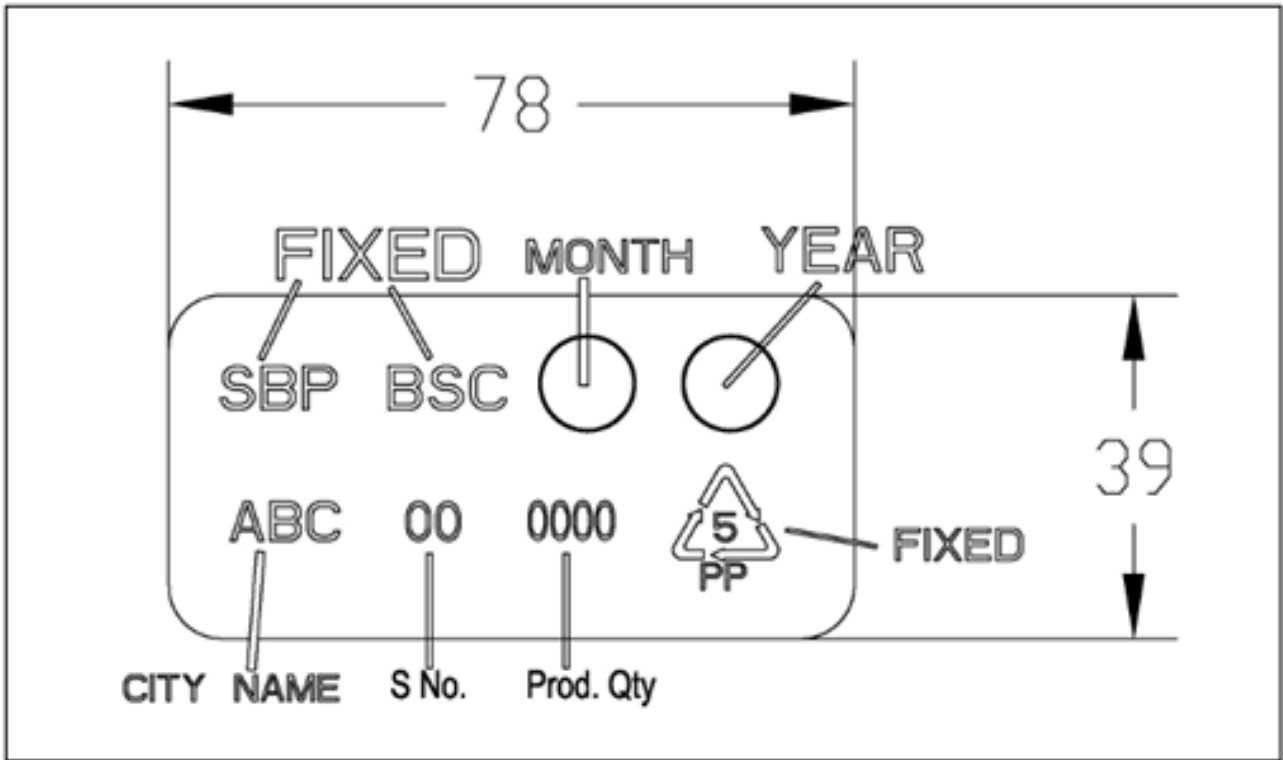

Batch Details will be shared by the Bank with the Most Advantageous Bidder after Notification of Award.

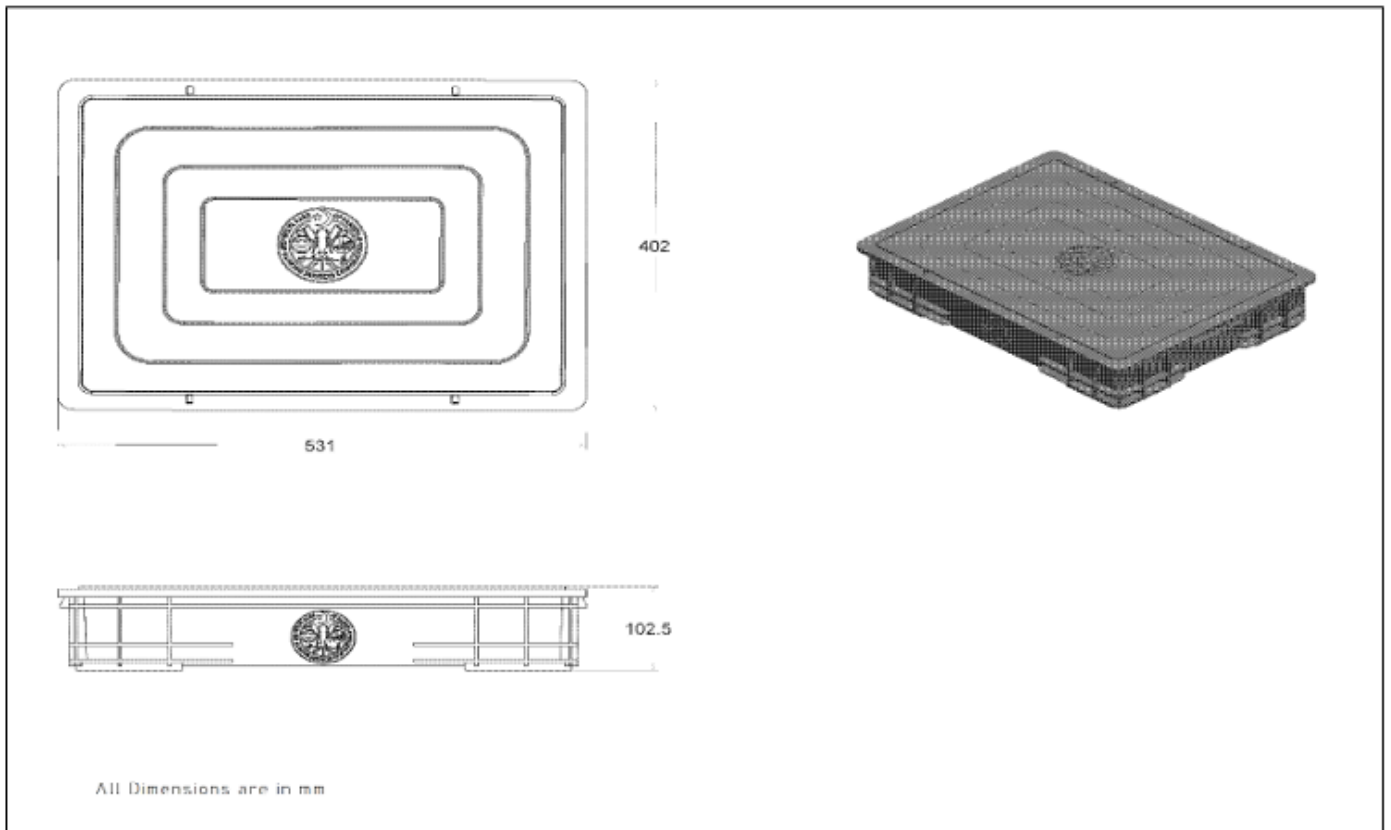

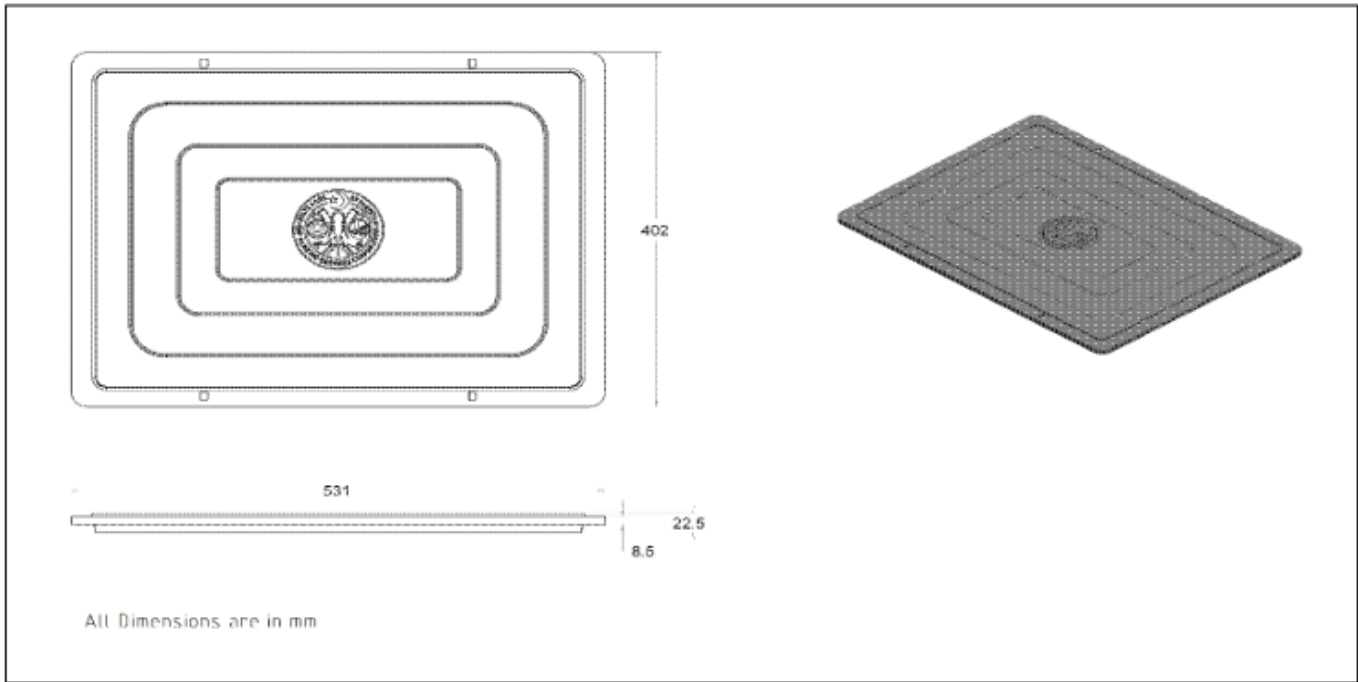

**Finalized look of the Product:**

